

# Pictures Out Of Thin Air

## - *The magic of Television*

Dr. Nimal Ratnayake  
Dept. of Electrical & Electronic Engineering  
University of Peradeniya

### 1 Introduction

Today, television has become a part of the life of everybody. It is preferred over radio or any other media by the public for entertainment and information. It is also a very attractive medium for advertisers. Also, thanks to the advancements in the field of television and telecommunication in general, billions of viewers around the globe can be watching an event on their color TV screens as it happens, as if they were witnessing the real event.

Television had a long way to come to this level of sophistication, and the journey began with the introduction of black and white (*monochrome*) television in the United States in 1932. Color television broadcasts began in 1954 with the introduction of NTSC color system in the United States. The PAL system, which is a variation of NTSC was introduced in Germany in 1967. A third color system called SECAM was introduced in France around the same time. All these systems have much in common, and we will restrict our attention to the CCIR PAL B system used in our country.

To put it in technical terms, television is the transmission of visual images plus sound using electrical signals. First of all, a television camera aimed at a scene converts the information in that scene into electrical signals. Very often the signal is processed in the studio (by recording and playback, adding special visual effects, etc.). The signal is then *modulated* so that it can be transmitted over air, and a transmitting antenna creates an *electro-magnetic* field in the atmosphere. When a receiving antenna is placed in this field, it generates a small electrical current, which is then used by the television receiver to create a picture and sound.

### 2 Scanning

But how exactly can a picture be converted into an electrical signal? The answer may be best explained by seeing what kind of information is needed by the television receiver to create a moving picture on the *picture tube*.

Although you see a moving picture on the television screen, what is actually there is a series of still pictures, at the rate of 25 pictures per second, to create the illusion

of continuous motion. We give the name *frame* for these still pictures. However, a frame is not created on the screen all at once, but in 625 steps and a frame is actually a collection of 625 lines as shown in figure 1. Let us label these lines sequentially from 1 to 625.

Another interesting fact about the creation of a frame is that the 625 lines are not drawn in sequence - that is line 3 is not drawn after drawing line 2. Instead, all the even numbered lines are drawn before drawing the odd numbered lines. Thus, a still picture of 625 lines is actually two still pictures consisting of 312.5 lines each, *interlaced* together. We use the term *field* for these half-pictures. To create 25 frames per second, we need to create 50 fields per second.

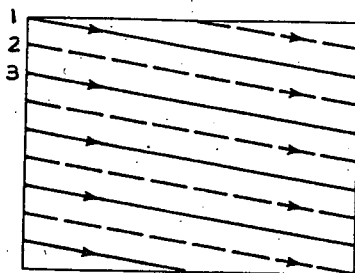

Figure 1: Creating a picture using lines. Solid lines represent the first frame, and dashed lines the second.

### 3 Picture tubes

How are these tiny lines created on the picture tube? Let us first consider a black and white picture tube. On the inside surface of the front of the picture tube is a coating of a material (*phosphor*) that emits light when hit by an electron beam. The beam used for this purpose is generated in the back of the picture tube using an *electron gun*. The stronger the beam of electrons, the brighter the light emitted by the phosphor. In order to create a picture made out of tiny lines, the beam needs to travel across or *scan* the picture tube. As the beam scans the tube, its intensity is changed according to the variation of brightness in the picture.

Also, after drawing each line, the beam needs to be brought back to the left hand side of the tube so that the next line can begin. Similarly, at the end of each field, the beam need to be brought back to the top of the screen so that the next field can begin. These two operations are called *horizontal retrace* and *vertical retrace* respectively. During retracing, the strength of the electron beam should be such that the retrace lines are not visible.

The same principal is used in color picture tubes, but instead of just one kind of phosphor, we have three types of phosphors - red, green, and blue. or the three *primary colors*. Also, instead of one electron beam, we need three electron beams

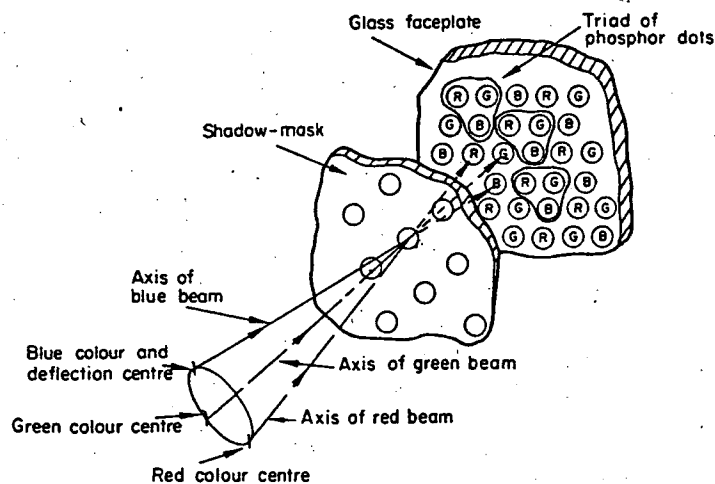

Figure 2: The shadow-mask color picture tube

to illuminate the three phosphor types. The red, green, and blue phosphors, when hit by an electron beam, will emit light of the respective color. The reason we have phosphors of only the primary colors is that most of the other colors can be created by adding varying quantities of the three primary colors. For example, white can be created by adding equal amounts of red, green and blue, and yellow can be created by adding equal amounts of red and green.

There are two ways in which these three phosphors can be arranged on the screen. The *shadow-mask* tube, developed by RCA Corporation of the United States, has tiny dots of red, green, and blue phosphors arranged in equilateral triangles (called a *triad*) on the glass faceplate of the picture tube as shown in figure 2. Behind the glass faceplate is the *shadow-mask* which has a hole for each triad of phosphor. In a typical tube, there are some 440,000 color triads and an equal number of holes in the shadow-mask. This arrangement of triads requires the three electron beams be spaced at 120 degree intervals around a common axis, as shown in the figure.

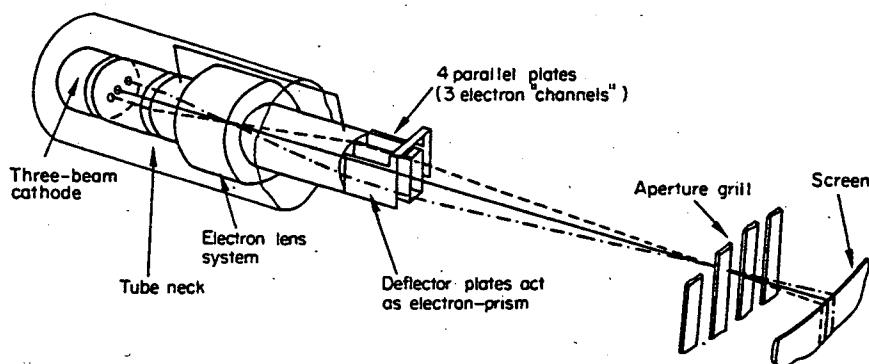

Figure 3: The trinitron color picture tube

The other type of color picture tubes is the *trinitron* developed by the Sony Corporation of Japan. In the trinitron tube, the color phosphors are arranged in vertical stripes, and the shadow-mask is replaced by a metal aperture grill, with one vertical slot for each phosphor triad as shown in figure 3. Also, instead of three separate electron guns producing three separate beams, a single gun which produces three in-line beams is used. In a typical tube, there are several hundred vertical phosphor triads.

## 4 The Video Camera

Now that we know how a picture is created on the picture tube of a television, we can relate that to the function of the video camera. The video camera should convert the picture that falls on its screen into an electrical signal which can be used by a picture tube to recreate the original picture. Therefore, it can be said that the task of the video camera is the opposite of that of the picture tube.

The video camera should scan the picture in exactly the same fashion as we discussed in section 2. At any instant during the scanning process, the camera must convert the color information of the point being scanned, in terms of red (R), green (G), and blue (B) quantities. It should also include some information to indicate the beginning of a new frame, a new field, and a new scan line. As discussed in section 2, the picture tube needs this information to blank out the beam during *retrace* and to position the beam(s) at the correct horizontal and vertical positions in the beginning of each frame, fields, and lines. The video camera provides *blanking* and *synchronisation* (or simply *sync*) information using a pulse at the beginning of each line.

## 5 The Composite Video Signal

Next, we turn our attention to how the color and blanking/sync information provided by a video camera can be transmitted over the air. The obvious solution would be to transmit the three color signals and the blanking/sync signal separately. However, it becomes necessary to combine all the above signals into one *composite video* signal and transmit that. This necessity arises from the requirement that a monochrome television receiver should be able create a black and white picture and a color receiver should be able to create a color picture using the same signal.

To fulfill the above requirement, the composite video signal provides the red, green, and blue (RGB) information in two parts: a *luminance* signal that indicates the brightness and a *chrominance* signal which bears extra information that is needed to recreate the original color. Thus, a monochrome television receiver which needs only brightness information can use the luminance signal and disregard the chrominance signal, while a color receiver can use both the signals.

The luminance signal  $Y$  is formed using the R, G, and B values according to

$$Y = 0.30R + 0.59G + 0.11B$$

To form the chrominance signal  $C$ , we form two intermediate signals called *color-difference* signals as follows:

$$U = 0.493(B - Y)$$
$$V = 0.877(R - Y)$$

The chrominance signal is then formed by using these two signals for *quadrature amplitude modulation* (QAM) of a color *sub-carrier* signal which has a frequency of 4.43361875 MHz. For the purpose of this article, it is sufficient to state that the *amplitude*  $C$  and the *phase*  $\phi$  of the QAM chrominance signal

$$C = \sqrt{U^2 + V^2}$$
$$\phi = \tan^{-1}(V/U)$$

can be used to determine the original values of  $U$  and  $V$ . However, to make this possible, the composite video signal should also contain a small sample of clean (unmodulated) color sub carrier as well. This portion of the composite signal consists of about 10 cycles of the color sub-carrier of the composite signal is called the *color-burst*. Figure 4 shows a portion of the waveform (corresponding to one scan line) of a composite video signal of a color bar picture.

## 6 The Television Signal

The next question is how the composite video signal can be transmitted over the air. Here, it should be kept in mind that we need to be able to transmit more than one television signal over the air. If the composite video signal is transmitted directly, it will not be possible to transmit another similar signal as they will interfere with each other. To solve this problem, the composite video signal is used to *modulate* the *amplitude* (Amplitude Modulation or AM) of a *carrier* signal of high frequency, and the resulting signal is transmitted. The advantage of modulation is that, as long as we use carriers of frequencies that differ sufficiently, there will be no interference.

The television signal should also contain sound (audio) information in addition to the video signal. This is done by using the sound signal to modulate the frequency (Frequency Modulation or FM) of a *sound carrier*. The resulting signal is then added to the AM vision signal.

## 7 Transmission Frequencies

In the previous section, we said that to avoid interference, the vision carrier frequencies used by two broadcasts need to be different. To ensure this, the frequency bands allocated for television broadcasts are divided into a number of *channels* and a vision carrier frequency is assigned for each channel. In the CCIR PAL B system, the *bandwidth* of a channel (the range of frequencies in a channel) is 7MHz. This bandwidth is shared by the AM vision signal and the FM sound signal. Figure 5 shows how the vision and sound information is spread over the bandwidth of a channel.

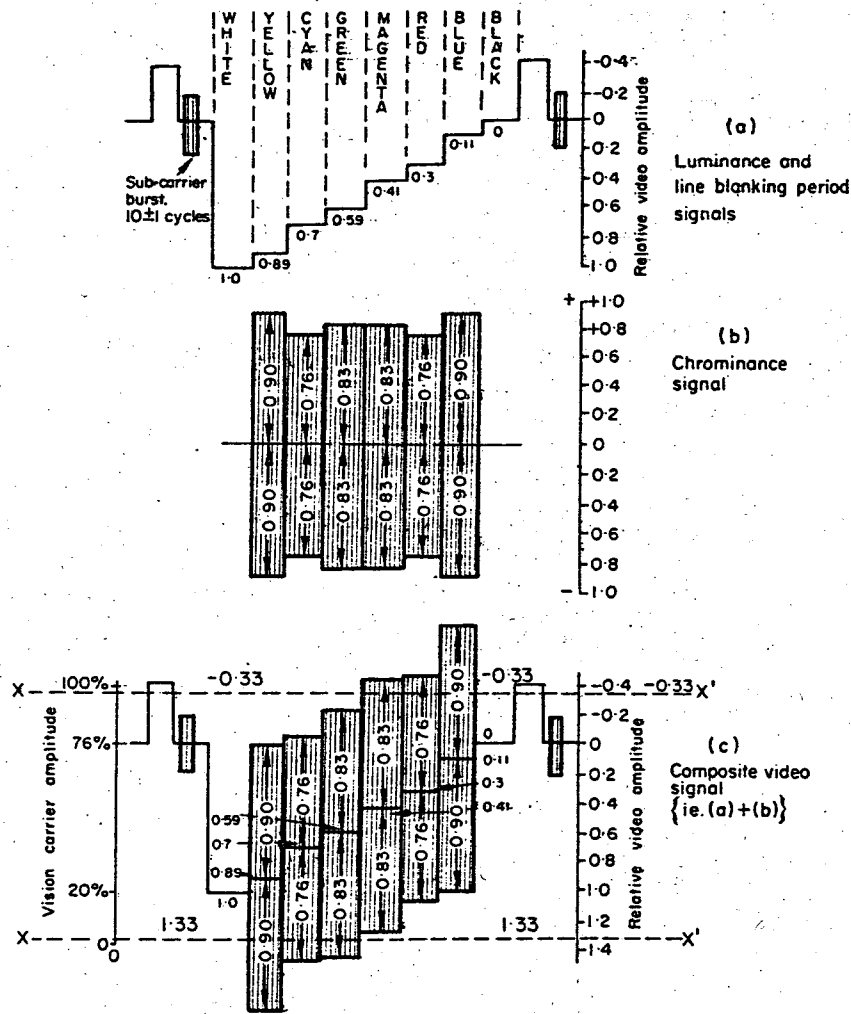

Figure 4: The waveform of a color bar signal

The vision carrier frequency is always 1.25 MHz above the lower boundary of the channel (and 5.75 MHz below the upper boundary of the channel). As a result, the vision carriers frequencies of adjacent channels also differ by 7MHz. The frequency of the sound carrier is exactly 6 MHz higher than the frequency of the vision carrier. Table 1 shows the frequency bands allocated for television, the channel numbers in each band, and the vision carrier frequencies.

## 8 Other Television Systems

Any discussion about television would be incomplete without a comparison of various systems used in countries around the world. To identify the differences between these systems, distinction is made between the **television system** and the **color system**. Currently, there are 14 television systems (A, B, C, D, E, F, G, H, I, K, L, M, and N), and 3 main color systems (NTSC, PAL and SECAM) in use. Table 2 summarizes the features of some of the television systems.

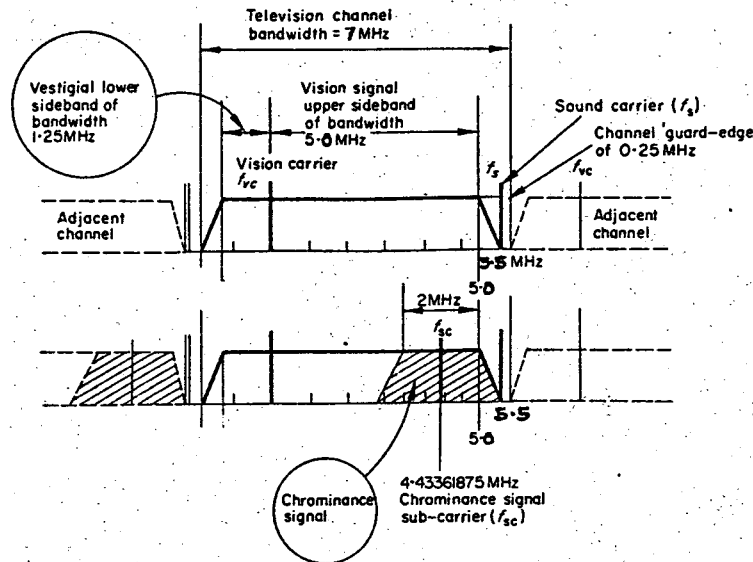

Figure 5: The television signal spectrum

Table 1: CCIR Television channel frequency assignments

Range	Frequency Range	Channel Numbers	Vision Carrier Frequencies
VHF	41 - 68 MHz	2 - 4	48.25 - 62.25
VHF	174 - 230 MHz	5 - 12	175.25 - 224.25
UHF	470 - 862 MHz	21 - 69	471.25 - 855.25

Because of the differences between systems, if a television receiver is not compatible with a particular television system, there will be severe distortions in the picture and sound. In particular, system M is totally incompatible with other systems since it uses 525 lines and a frame rate of 30 Hz, instead of 625 lines and a frame rate of 25 Hz. Other systems such as B, G, I, and L have the same number of lines and the frame rate, so an incompatible signal will produce at least a black and white picture. A receiver will also produce a black and white picture if it receives a signal of a compatible television system but a non-compatible color system.

Among the color systems, the only difference between NTSC and PAL is that the latter uses phase alternation from line to line in the color sub-carrier. The difference between PAL and SECAM color systems is that in SECAM, frequency modulation (FM) is used instead of Quadrature Amplitude Modulation (QAM) used in PAL. Also, in SECAM, only one color difference signal is given for a line, and the other color difference signal is given with the next line.

Also, the division of frequency bands into channels is not done according to a single standard. Most of the countries that use one of the PAL systems use the

Table 2: Characteristics of television systems

System	No. of lines	Bandwidth (MHz)	Vision Bandwidth (MHz)	Sound/Vision Separation (MHz)	Sound Modulation	Countries Used
B	625	7	5.0	+5.5	FM	Sri Lanka, Western Europe (VHF)
G	625	8	5.0	+5.5	FM	Western Europe (UHF)
I	625	8	5.5	+6.0	FM	UK
L	625	8	6.0	+6.5	FM	France
M	525	6	4.2	+4.5	FM	USA, Japan

CCIR channel assignments, while countries that use NTSC system follow the US assignments. There are few other channel systems in use as well.

It should be noted that the terms NTSC, PAL and SECAM are sometimes used to refer to a popular combination of a television system and a color system. For example what is normally called NTSC is actually television system M and color system NTSC, while what we call PAL B is television system B and color system PAL.

In addition to the systems we discussed above, a new standard called HDTV is also being developed. It is designed to overcome some of the problems with the existing systems, and provide a picture of better quality. Unlike other systems, it is expected that there will be a single HDTV standard worldwide, although the world has not been able to agree to a single standard yet. The proposed HDTV system has an aspect ratio (ratio of screen width to height) of 5:3 while that of all the current systems is 4:3. The number of scan lines in HDTV is 1125 and its video bandwidth is about 27 MHz. Compared to the current systems, HDTV would indeed be High Definition TV!